

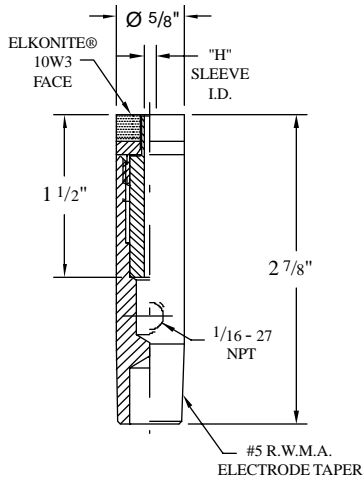

CHAMELEON/MAX-LIFE™ STUD WELDING ELECTRODES

T.J. Snow Co. (423) 894-6234; FAX: (423) 490-2417 (authorized distributor CMW Inc.)

Stud Welding Assemblies	Screw Thread Size	"H"	CMW® 3 Base	Ceramic Coated Stainless Steel Sleeve	Elkonite® Faced Cap
16-37325-116	#4	.116	16-37325	16-953116	16-37325-C116
16-37325-132	#5	.132	16-37325	16-953132	16-37325-C132
16-37325-140	#6	.140	16-37325	16-953140	16-37325-C140
16-37325-169	#8	.169	16-37325	16-953169	16-37325-C169
16-37325-169	4MM	.169	16-37325	16-953169	16-37325-C169
16-37325-191	#10	.191	16-37325	16-953191	16-37325-C191
16-37325-204	5MM	.204	16-37325	16-953204	16-37325-C204
16-37325-220	#12	.220	16-37325	16-953220	16-37325-C220
16-37325-243	6MM	.243	16-37325	16-953243S	16-37325-C243
16-37325-254	.250	.254	16-37325	16-953254S	16-37325-C254

Stud Welding Assemblies	Screw Thread Size	"H"	CMW® 3 Base	Ceramic Coated Stainless Steel Sleeve	Elkonite® Faced Cap
16-37525-243	6MM	.243	16-37825	16-953243	16-37525-C243
16-37525-254	.250	.254	16-37825	16-953254	16-37525-C254
16-37525-320	.312	.320	16-37825	16-953320	16-37525-C320
16-37525-320	8MM	.320	16-37825	16-953320	16-37525-C320
16-37525-380	.375	.380	16-37825	16-953380	16-37525-C380

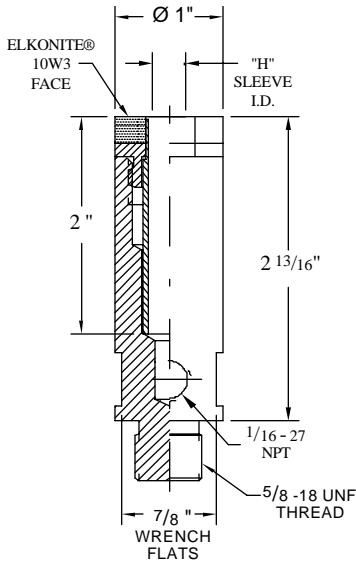
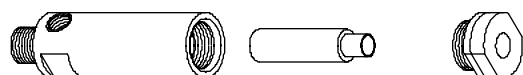
Stud Welding Assemblies	Screw Thread Size	"H"	CMW® 3 Base	Ceramic Coated Stainless Steel Sleeve	Elkonite® Faced Cap
16-37526-399	10MM	.399	16-37526	16-953399	16-37526-C399
16-37526-444	.438	.444	16-37526	16-953444	16-37526-C444
16-37526-477	12MM	.477	16-37526	16-953477	16-37526-C477
16-37526-502	.500	.502	16-37526	16-953502	16-37526-C502
16-37526-630	.625	.630	16-37526	16-953630	16-37526-C630

FOR 5/8" DIA. • USE COOLING CHAMBER 18-1340 P.24

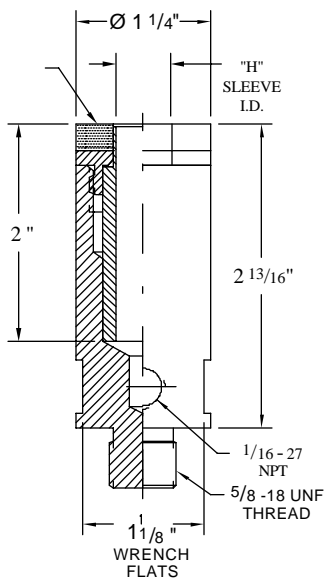
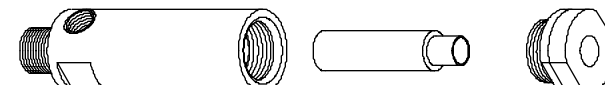
FOR 1" DIA. • MAY BE USED WITH HOLDERS 18-169, 18-170, 18-171 P.29
 AND 1 1/4" DIA. • FOR USE WITH PLATEN MOUNTED HOLDERS USE ADAPTER 18-7743 P.27
 • HOLDERS WITH 5RW TAPERS USE ADAPTERS 18-7741, 18-7742 P.23
 • USE COOLING CHAMBERS 18-1342, 18-1343 P.24