

# ADAPTERS

T.J. Snow Co. (423) 894-6234; FAX: (423) 490-2417 (authorized distributor CMW Inc.)



## MALE TAPER TO FEMALE TAPER ADAPTERS

ADAPTER PART NO.	MALE TAPER			FEMALE TAPER		Length Under Head M	Hex. Over Flats H	Overall Length C
	Size L	Minor Dia. J	Dia. @ 1/2" K	Size D	Major Dia. A			
<b>18-741</b>	5RW or 2MT	.588	.613	4RW or 1MT	.463	7/8	7/8	1 3/16
<b>18-742</b>	7RW or 3MT	.819	.844	5RW or 2MT	.613	1 3/16	1	1 1/2
<b>18-7414</b>	6RW	.706	.731	5RW	.613	7/8	1	1 3/16
<b>18-7415</b>	4RW or 1MT	.438	.463	5RW or 2MT	.613	5/8	7/8	1 3/4
<b>18-7416</b>	5RW or 2MT	.588	.613	6RW	.731	7/8	1	2 1/4

## MALE PIPE THREAD TO FEMALE TAPER ADAPTERS

ADAPTER PART NO.	MALE THREAD Size L	FEMALE TAPER		Length Under Head M	Hex. Over Flats H	Overall Length C
		Size D	Maj. Dia. A			
<b>18-746-07</b>	1/2-14 pipe	4RW or 1MT	.463	5/8	1	7/8
<b>18-747-07</b>	1/2-14 pipe	5RW or 2MT	.613	5/8	1	7/8
<b>18-7465-07</b>	1/2-14 pipe	5RW MALE CAP	.414	9/16	7/8	7/8
<b>18-748-06</b>	5/8-14 pipe	4RW or 1MT	.463	9/16	1	3/4
<b>18-749-06</b>	5/8-14 pipe	5RW or 2MT	.613	9/16	1	3/4
<b>18-756-09</b>	3/4-14 pipe	4RW or 1MT	.463	7/8	1 1/4	1 1/8
<b>18-757-09</b>	3/4-14 pipe	5RW or 2MT	.613	7/8	1 1/4	1 1/8
<b>18-7576-09</b>	3/4-14 pipe	6RW	.731	7/8	1 1/4	1 1/8

\*Adapters of longer lengths available in 1/8" increments upon request

## MALE THREAD TO FEMALE TAPER ADAPTERS

ADAPTER PART NO.	MALE THREAD Size L	FEMALE TAPER		Length Under Head M	Dia. Or Hex H	Overall Length C	Sealing Ring Part No.
		Size D	Major Dia. A				
<b>18-750</b>	5/8-18	4RW or 1MT	.463	9/16	7/8 Hex	13/16	18-10060-11
<b>18-751</b>	5/8-18	5RW or 2MT	.613	9/16	1 Hex	1 11/16	18-10060-11
<b>*18-755</b>	3/4-10	5RW or 2MT	.613	9/16	1 Dia.	1 9/16	18-10060-12
<b>18-770</b>	7/8-14	4RW or 1MT	.463	5/8	1 Hex	13/16	18-76460
<b>18-771</b>	7/8-14	5RW or 2MT	.613	5/8	1 Hex	13/16	18-76460
<b>18-7743</b>	1-14	5/8 - 18 THD	-	5/8	1 1/4 Hex	1	18-10060-17
<b>18-785</b>	1-14	4RW or 1MT	.463	9/16	1 1/4 Hex	13/16	18-10060-17
<b>18-786</b>	1-14	5RW or 2MT	.613	9/16	1 1/4 Hex	13/16	18-10060-17
<b>18-7863</b>	1-14	6RW	.731	3/4	1 1/4 Hex	1 3/4	18-10060-17
<b>18-787</b>	1-14	7RW or 3 MT	.844	3/4	1 1/4 Hex	2 1/8	18-10060-17
<b>18-7875</b>	1-14	5RW or 2MT	.613	9/16	1 1/4 Dia.	1 1/16	18-10060-17
<b>18-7876</b>	1-14	6RW	.731	5/8	1 1/4 Dia.	7/8	18-10060-17

\*This part has 3/4" wrench flats.

## FEMALE THREAD TO FEMALE TAPER ADAPTERS

ADAPTER PART NO.	FEMALE THREAD Size L	FEMALE TAPER		Outside Dia. B	Over Wrench Flats H	Overall Length C
		Size D	Major Dia. A			
<b>18-753</b>	5/8-18	4RW or 1MT	.463	1 1/4	3/4	1 5/8
<b>18-754</b>	5/8-18	5RW or 2MT	.613	1 1/4	3/4	1 5/8
<b>18-7591</b>	3/4-10	4RW or 1MT	.463	1 1/4 Hex	1 1/4	1 3/4
<b>18-7592</b>	3/4-10	5RW or 2MT	.613	1 1/4 Hex	1 1/4	1 3/4

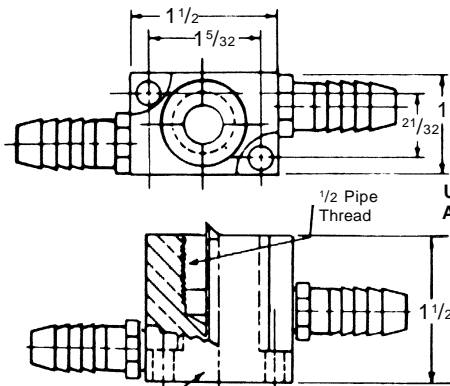

18-82650 ADAPTER ASSY 1/2 - 14 PIPE THD.

USE WITH 1/2 PIPE THREAD ADAPTERS LISTED ON THIS PAGE

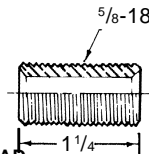

ADAPTER PART NO. 18-752

See page 6 for Metric conversions  
See page 7 for Taper dimensions

See page 30 for Ejector type Adapters